

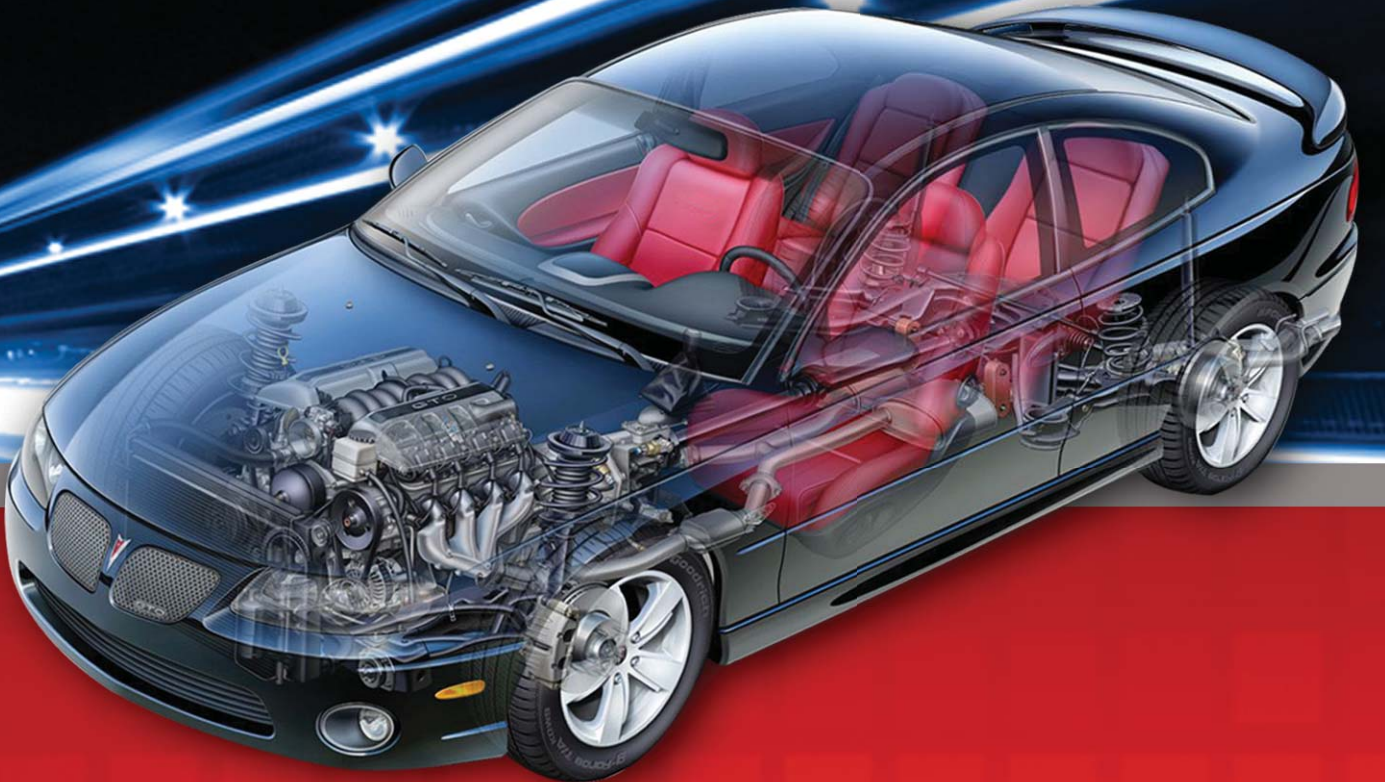

MAKİNA KALIP SANAYİİ  
VE TİC. A.Ş.

**Success is a Journey  
Not a Destination**





- FARKLI ÜRÜN TEKNOLOJİLERİNİN BÜTÜNLEŞMESİ
- TASARIM DESTEK YETENEĞİ
- OTOMATİK HATLARIN ADAPTASYONU
- VERİMLİLİK-TASARRUF
- KALİTE
- FİZİBİLİTE
- YALIN ÜRETİM
- SÜREKLİ EĞİTİM



## **NEDEN AL-KOR / WHY AL-KOR**

- INTEGRATION OF DIFFERENT PRODUCTION TECHNOLOGY.
- DESIGN SUPPORT ABILITY.
- ADAPTATION OF AUTOMATED LINES
- INNOVATION-SAVING
- QUALITY
- FEASIBILITY
- LEAN PRODUCTION
- TRAINING
- SUSTAINABILITY

## HAKKIMIZDA / ABOUT US



Firmamız **AL-KOR**, 1970 yılında Dolapdere'de 80m<sup>2</sup> alanda faaliyetine başlamıştır günümüzde 8400m<sup>2</sup> alanda devam etmektedir. Başta Avrupa ülkeleri olmak üzere; Asya, Afrika ve Amerika kıtalarında bulunan ülkelere ihracat yapmaktadır. Gelişen teknoloji, değişen müşteri talep ve beklentilerine göre imal ettiği ve geliştirdiği ürünlerini, uzman kadrosu, bilgi birikimi ve üstün standardı ile sunan **AL-KOR**, alanındaki liderliğini sürdürmektedir.

**AL-KOR**, Kalıp Tasarım, Kalıphane, Plastik Enjeksiyon, Pres Metal İşletme ve Saç İşlevleri, Otomasyon Montaj ve Test Bölümleri ve Kalite Yönetim Bölümleri ile Beylikdüzü ve Hadımköy adreslerinde hizmet vermektedir.

**AL-KOR**, AQA (American Quality Assessors) ISO 9001:2000 ve TS 16949: 2002 kalite sertifikalarına sahiptir.

**AL-KOR**, otomotiv sektörü başta olmak üzere, telekomünikasyon, beyaz eşya, CNC, CAD, CAM ve kamera teknolojilerini kullanarak aşağıdaki konularda hizmet vermektedir;

**Kalıp ve otomasyon tasarımları:** Her türlü metal, plastik ve programlı kalıp imalatları, montaj, test aparat ve cihazları ile otomasyon makinaları ve hatları

**Saç işlevleri:** Kesme, sıvama, bükme, eğme, ezme, form derin çekme işlemleri

**Enjeksiyon işlemleri:** Plastik enjeksiyon işlemleri (insertli, çift komponentli ürünler)

**Metal işleme**





Our company **AL-KOR** currently continues its activities on an area of 8400m<sup>2</sup> where it was started up in 1970 on an area of 80m<sup>2</sup> in Dolapdere / Istanbul.

**AL-KOR**, which provides production and development in accordance with the developing technology, changing customer demands and expectations with its specialized personnel, knowledge, and superior service standards, sustains its leadership within the sector.

**AL-KOR**, supplies its services in Beylikduzu and Hadimkoy with its Mould Design, Mould Workshop, Plastic Injection, Press Metal Machining and Sheet Functions, Automation Assembly and Test Departments and Quality Management Departments.

**AL-KOR** holds AQA (American Quality Assessors), ISO 9001: 2000 certificate and TS 16949: 2002 Quality Certificate.

**AL-KOR** supplies services for automative sector in major, telecommunication, white goods and electrical sector on the following fields by using CAD, CAM, CNC and camera technologies;

**Mould and Automation Designs:** All kinds of metal, plastic and progressive mould manufacture, assembly and test apparatus and instruments and automated machines and lines.

**Sheet Functions:** Cutting, bending, twisting, stamping and deep form rolling functions.

**Injection Processes:** Plastic injection processes (products with inserts and double components).

**Machining**



## TEKNİK BÜRO / TECHNICAL OFFICE



Tasarım destekli çalışmalar  
*Co-Design oriented studies*

### CAD&CAM SOFTWARES

#### CAD

- UNIGRAPHICS
- CATIA
- IDEAS
- SOLIDWORKS
- AUTOCAD



#### CAM

- MACHINING STRATEGY
- POWERMILL
- NCBRAIN

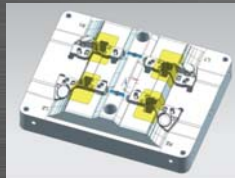

Plastik enjeksiyon kalıplarında  
moldflow analizi  
*Moldflow analysis on plastic injection  
moulds*

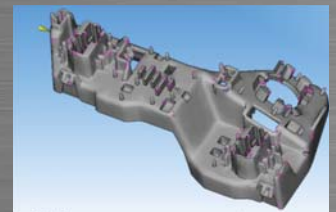
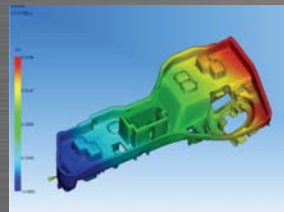
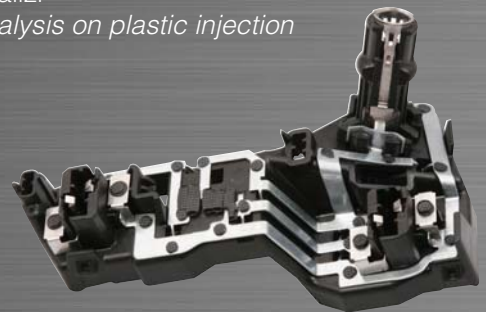

Saç kalıplarında  
Autoform analizi  
*Autoform analysis on  
sheet metal moulds*

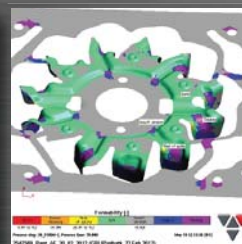
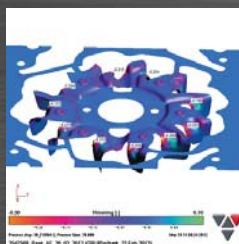

## KALIPHANE / MOULD SHOP



Kalip imalatı  
*Tool production*



Plastik enjeksiyon kalıpları,  
prograsif ve operasyonel metal parça  
kalıpları

*Plastic injection moulds,  
progressive and operational metal parts tools*

### AVAILABLE MACHINES (Mould Shop)

CNC MILLING

CNC WIRE EDM

CNC ELECTRO EROSION

ELECTRO EROSION

TURNING MACHINES

MILLING MACHINES

DRILLING





## PLASTİK ENJEKSİYON / PLASTIC INJECTION



Plastik Enjeksiyon hatları ve Merkezi kurutma, besleme, ve dağıtım ünitesi ile kaliteli üretim  
*Plastic Injection lines and Quality production with the centralised drying, feeding and conveying system*

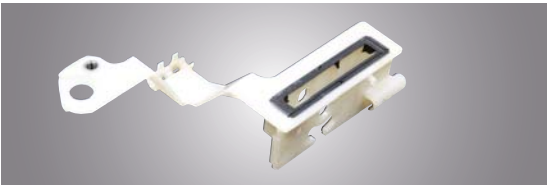





Plastik Enjeksiyonlu makinaların otomasyon ile entegrasyonu sonucunda elde edilen verimlilik  
*Efficiency of plastic injection machines which is resulting from integration with automation.*

**380 Tona kadar enjeksiyon kapasitesi**  
**Overmolding Parçalar,**  
**çift komponentli parçaların üretimi**  
**Injection machines up to 360 tons**  
**Overmolding parts,**  
**double sided**  
**component parts production**



## PRESHANE BÖLÜMÜ / PRESS SHOP



500 Ton'a kadar Eksantrik ve Hidrolik Pres Parkuru  
*Hydraulic and Eccentric Presses up to 500 Tons*



Formlu parça üretimi ve kaynak operasyonu  
*Production of formed parts and welding operations*





Prograsif kalıplara otomasyon uyarlaması  
*Adaptation of automation to progressive moulds*



Sivama Kalıpları ile dar toleranslı Parçalar  
*Deep small parts with small tolerance weights*



## AYDINLATMA / LIGHTING PARTS



Montaj ve test makinaları  
Assembly and testing machines



Ampul duyları  
Bulb sockets



Sis farı reflektörleri  
Fog lamp reflectors

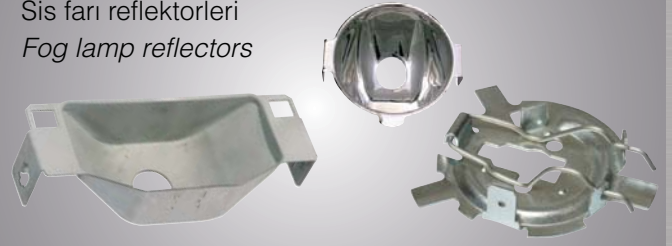

Ampul tutucuları  
Bulb Holders

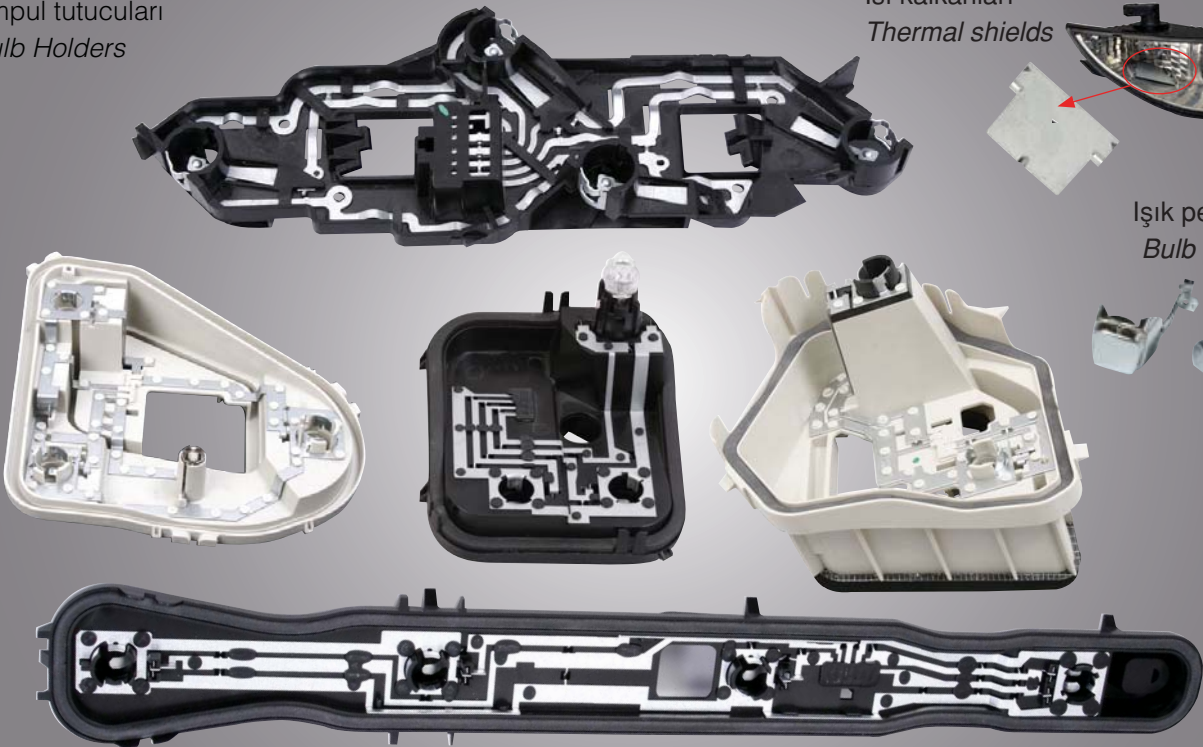

Isı kalkanları  
Thermal shields



Işık perdeleri  
Bulb shields



## SİLECEK GRUBU / WIPER SYSTEMS



Birleşik sistemli silecek kabiliyeti  
*Wiper system component capabilities*

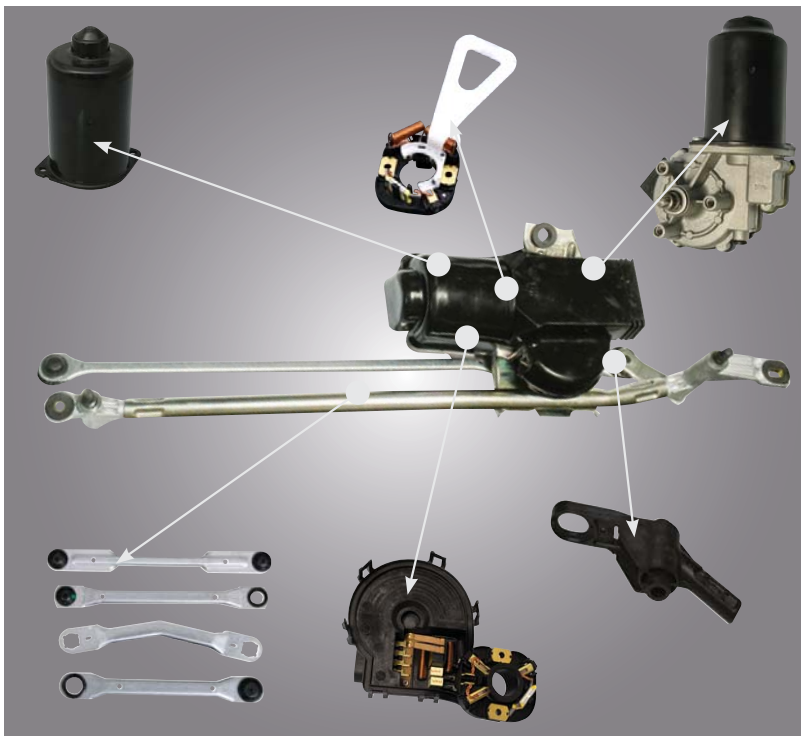

- Wiper Arms (overmolded)
- Deep Drawn Housing
- Plastic Covers
- Brush Holders
- Cranks
- Plastic Pivot Housing



## ALTERNATÖR PARÇALARI / ALTERNATOR PARTS



Insert'li parçalar  
*Inserted parts*

Plastik kaplamalar  
*Plastic covers*



*Metal Inserted Parts*





## OTOMASYON

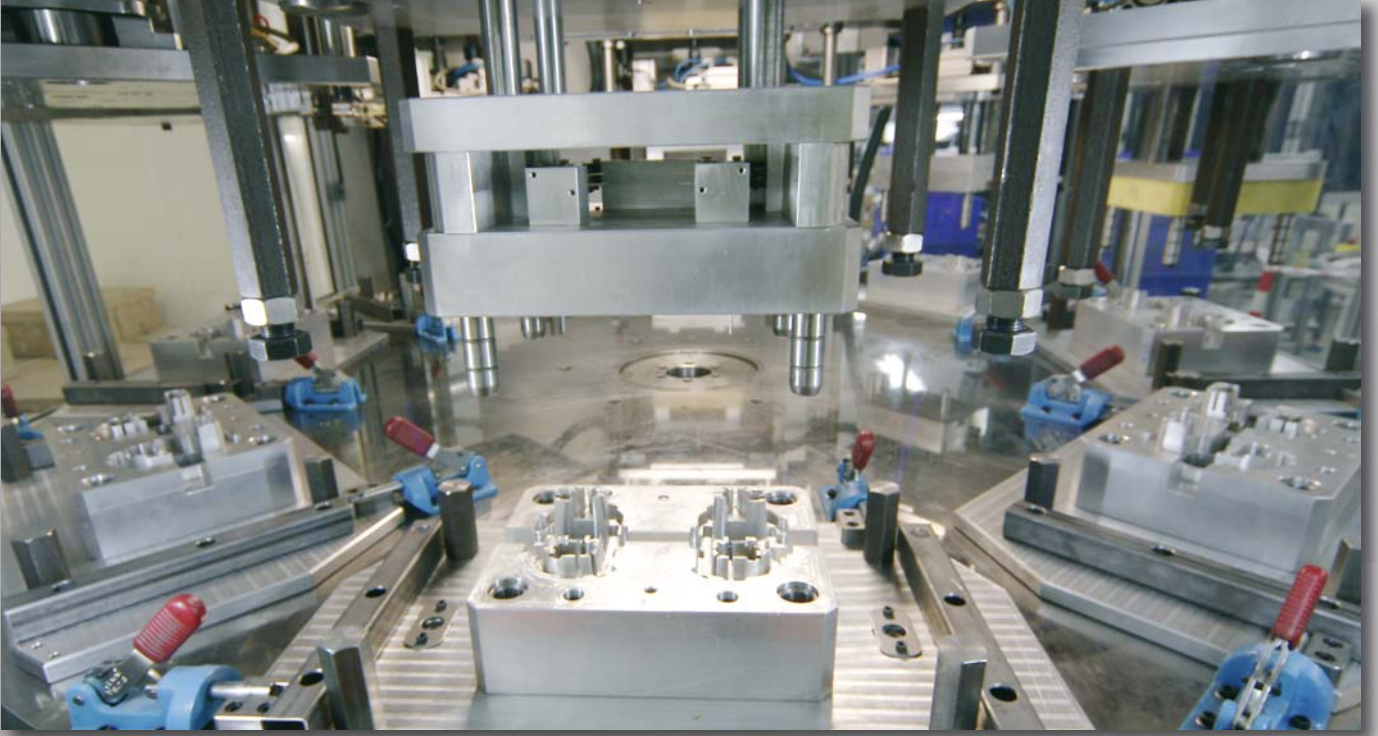

Döner tablalı otomasyon hatları  
*Turntable automation lines*

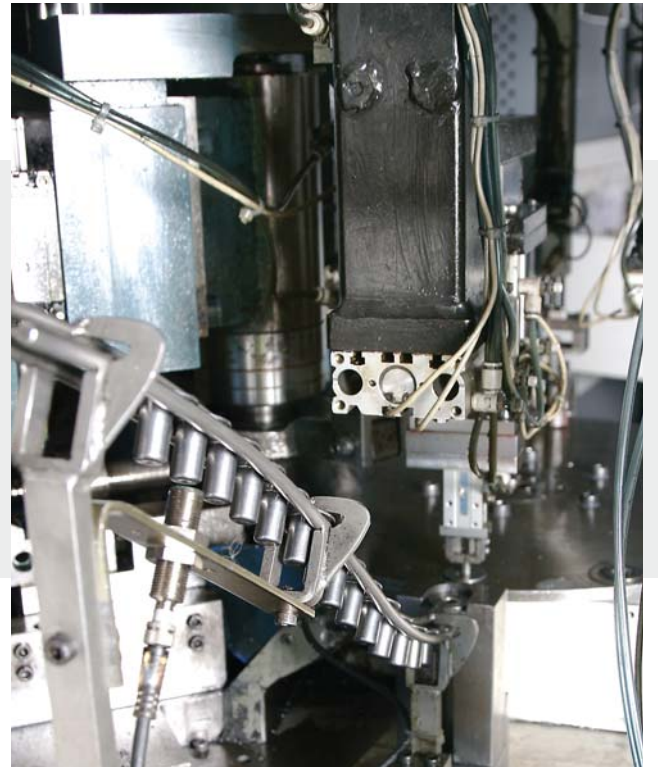



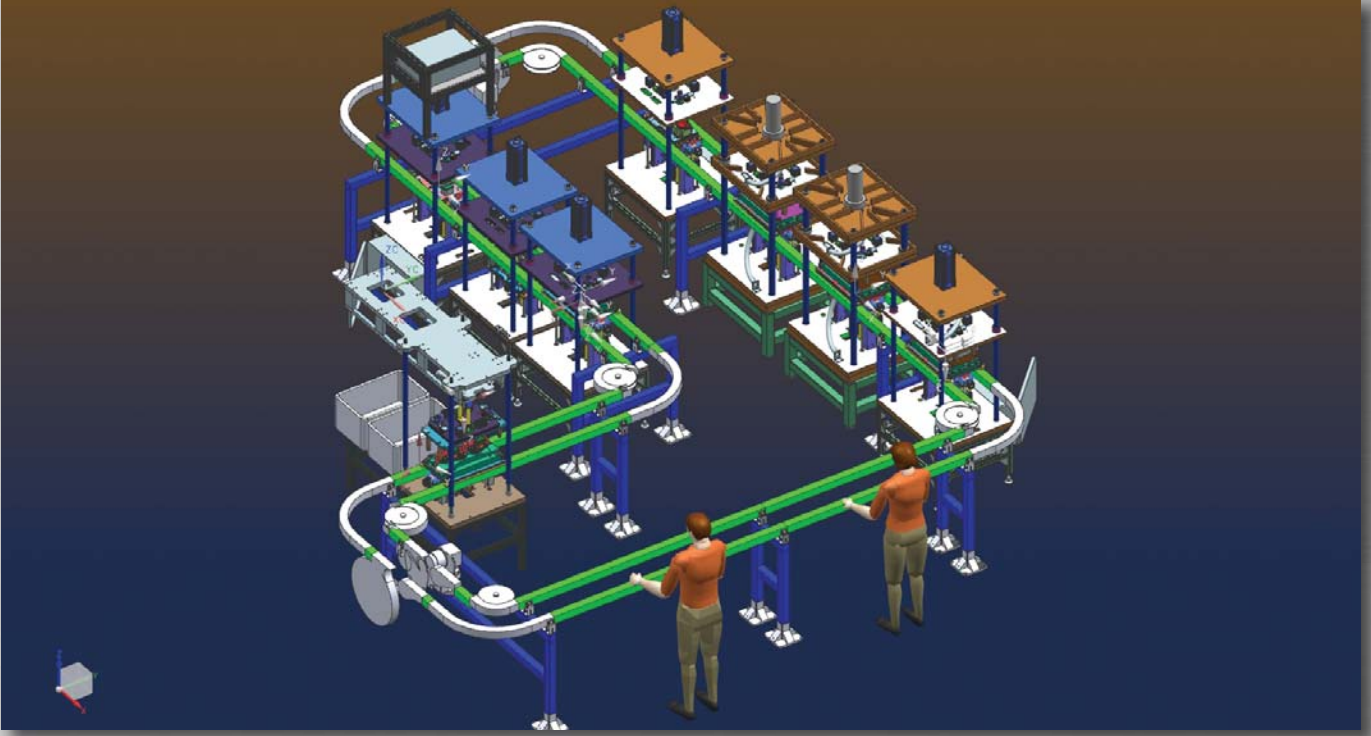

Flexible otomasyon hatları  
*Flexible automation lines*

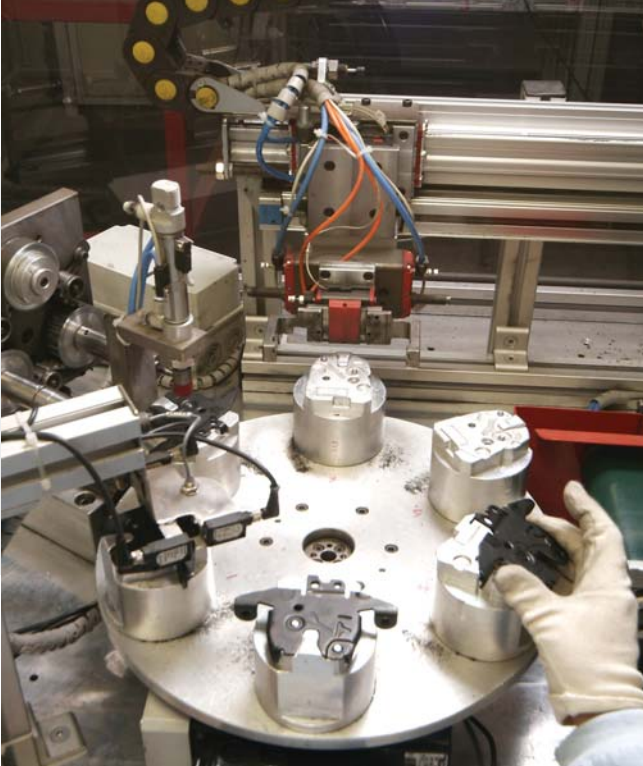

## Otomasyon Kabiliyetimiz

- Yüksek hız
- Yüksek verimlilik
- Yüksek kalite

## *Automation capabilities*

- *High speed*
- *High productivity*
- *High quality*

## HAVALANDIRMA PARÇALARI / CLIMATING SYSTEMS PARTS



Birleşik sistemli havalandırma sistemleri  
*Composite climating systems*

Hava kanalları  
Plastik vanalar (Basit ve çift enjeksiyonlu)



*Air Channels  
Plastic Valves (Simple and bi-injected)*



quality  
kalite

competitiveness  
rekabet

fast project  
hızlı proje

development  
geliştirme

flexibility  
esneklik

güven  
trust

  
**AL-KOR**



MAKİNA KALIP SANAYİİ  
VE TİC. A.Ş.



**Eksen** ajans 212 292 01 99

Makina Kalıp ve Ticaret A.Ş.  
Bakırcılar ve Pirinçciler Organize Sanayii Sitesi Leylak Cad. No: 12 34524  
Beylikdüzü / İSTANBUL  
Tel: +90 212 876 58 20 (pbx)  
Faks: +90 212 876 5826  
[www.al-kor.com.tr](http://www.al-kor.com.tr)